

## AC INTEGRATED FLYWHEEL GENERATOR

230 V 50Hz | 110 V 60Hz

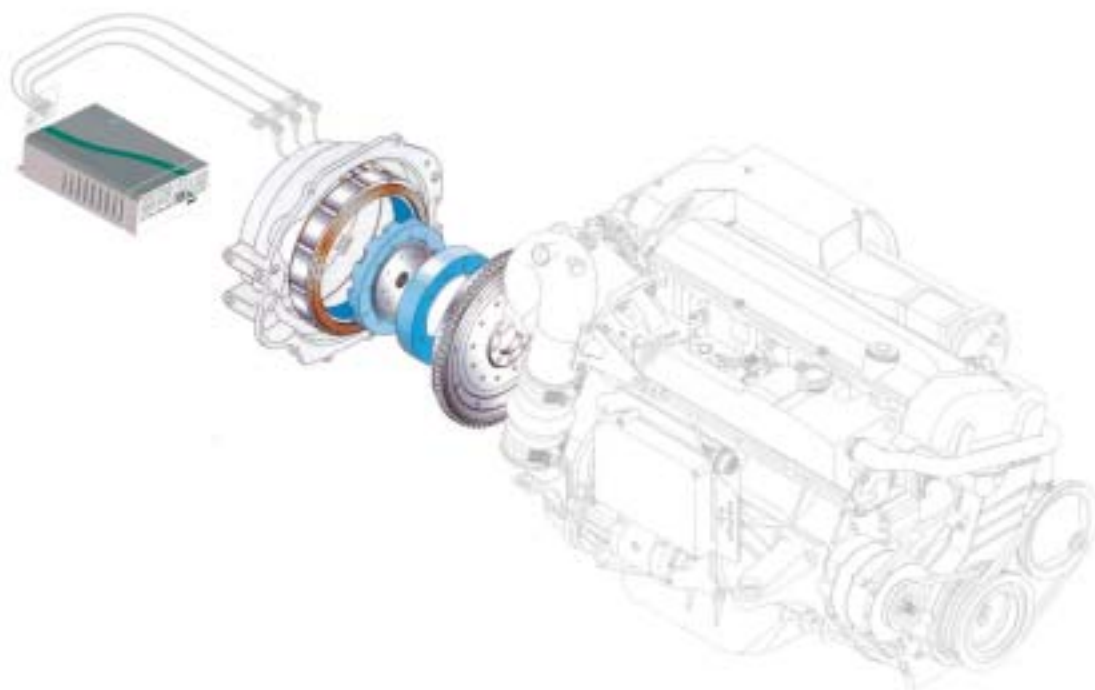

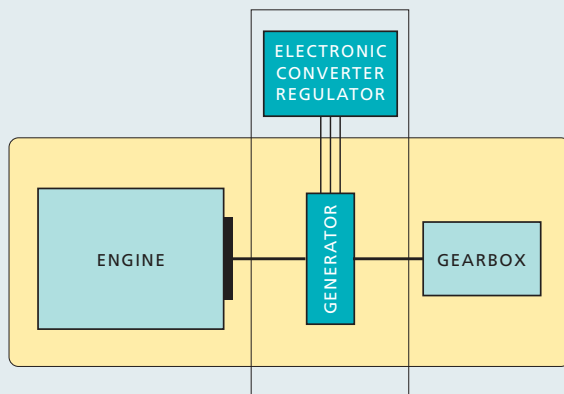

AIZ integrated generator

### MAIN TECHNICAL DATA

Type	AIZ 230 V 50Hz	AIZ 110 V 60Hz
Nominal voltage (V)	230	110
Frequency (Hz)	50	60
Short time output power (kW)	6	6
Continuous output power (kW)	4	4
Stator diameter (mm)	300	300
Stator weight (kg)	8.5	8.5
Rotor weight (kg)	7.5	7.5
Max speed (rpm)	4700	4700
Stator cooling	Liquid	Liquid
Electronic converter regulator cooling	Air	Air
Electronic converter regulator dimensions (mm)	426 x 265 x 107	426 x 265 x 107
Electronic converter regulator weight (kg)	9.4	9.4

### APPLICATIONS

Iskra 230 V 50Hz or 110 V 60 Hz AC generators are intended for applications in the systems with high AC electric energy requirements. Generators are primarily designed to be built on the flywheel of the internal combustion engine as compact integrated flywheel generator. For the use in the renewable energy sources through water or wind turbines, the autonomous AC generators can be built. Iskra AC generators are of high quality. They are designed and built according to the customer needs for stationary, portable or mobile applications. Integrated or autonomous AC generators are mainly suitable for:

- Boats and other marine applications
- Special needs on road vehicles
- Special needs on off-road vehicles
- Stationary or portable electric power sets
- As emergency power supply

The generator is designed to be built on the engine between the engine and the gearbox.

### FEATURES

- High efficiency (>85%)
- High specific power
- Constant output voltage 230 V 50 Hz or 110 V 60 Hz in wide range of speed of rotation
- Separate electronic converter regulator
- Very stable and low harmonics sine wave voltage on generator output
- Electronic regulator with communication and remote control options
- Maintenance free solution
- Over-current and temperature protection
- Compact design
- EMC compatible

### DESIGN

Iskra's integrated 230 V 50 Hz or 110 V 60 Hz generator is based on a three-phase brushless permanent magnet synchronous generator. The system includes a stator, rotor, housing and separate electronic converter regulator enabling a constant output independent of the variable engine speed. The output enables alternative 230 V 50 Hz or 110 V 60 Hz output voltage for power up to 4 kW continuously. The compact construction and the mode of mounting make it possible to reduce the mounting space at high output power. Carefully selected materials assure improved technical characteristics, long life and maintenance free operation even under harshest conditions.

### Stator

The stator is a three-phase winding on the laminated pack. Construction and high filling factor of the stator windings provide high power output. For nominal output power, adequate water cooling must be provided through the flywheel housing defined by the customer.

### Rotor

The rotor is designed with high-energy rare earth permanent magnets and no wearing parts, what assures long life and maintenance free operation.

### Electronic converter regulator

The separate electronic converter regulator provides a stable 230 V 50 Hz or 110 V 60 Hz output independent of the rotor speed and the electric output loads. Electric system is not sensitive to sudden and short time overloads. This electronic converter regulator has internally controlled air-cooling; therefore no additional cooling installation is required.

GENERATOR AND REGULATOR DIMENSIONS

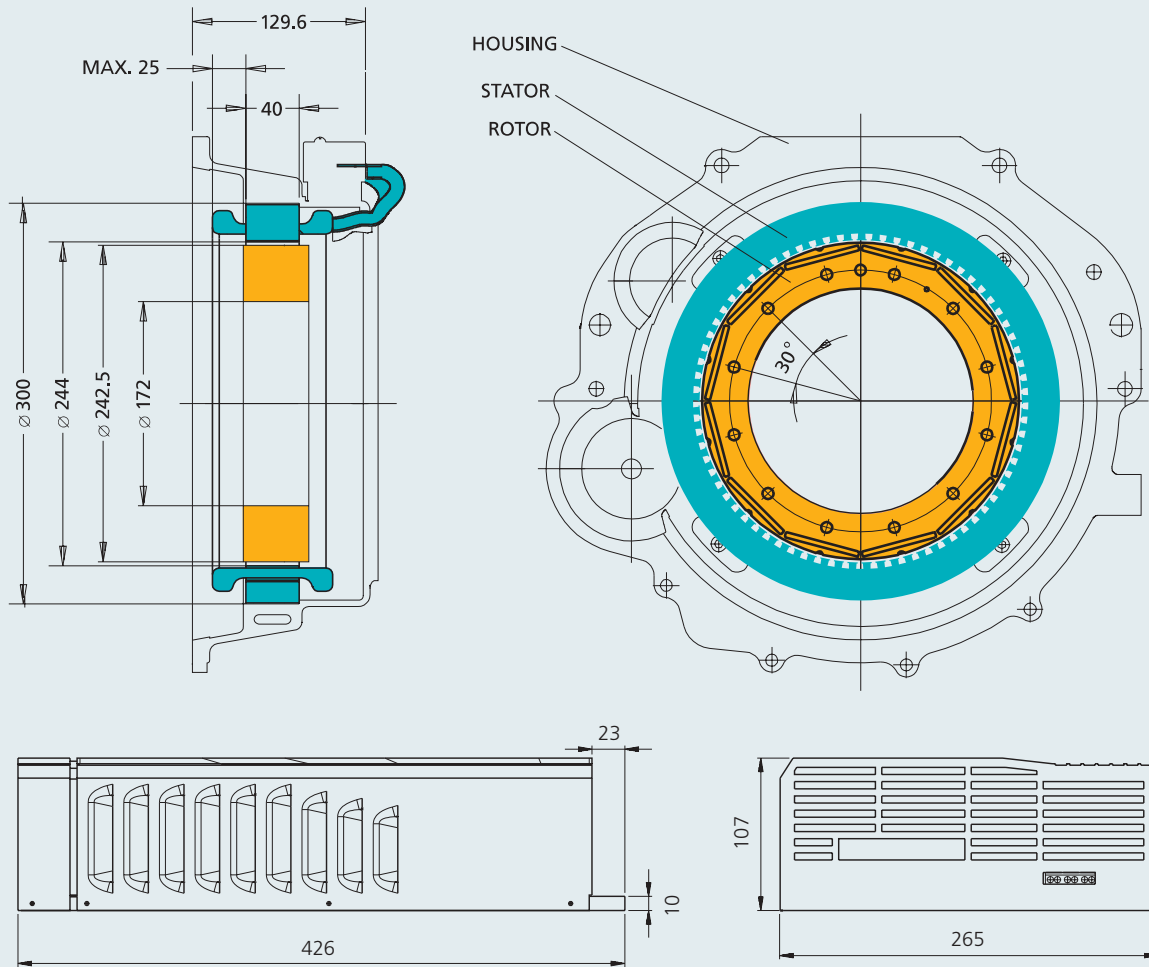

CHARACTERISTIC

- Output power
- Efficiency

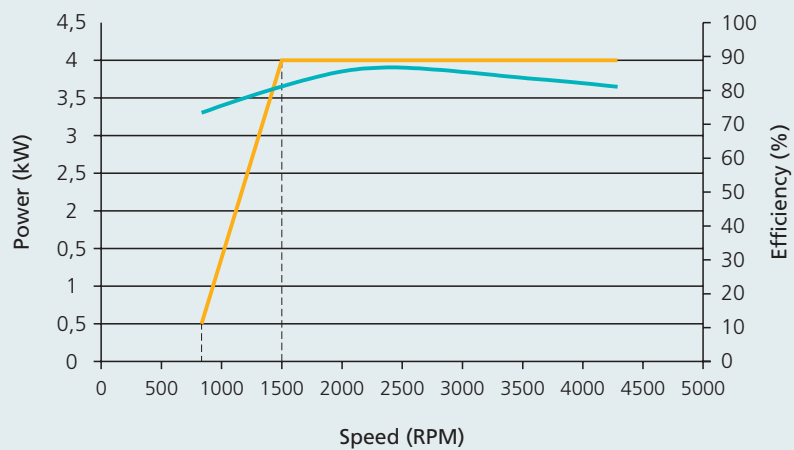

CONNECTION DIAGRAM

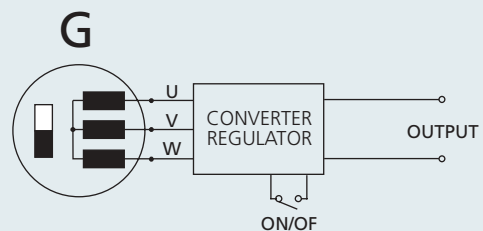

NOTE: For installation details see special instructions or contact us.

**Iskra Avtoelektrika, d. d.**

Polje 15, Slovenia, 5290 Šempeter pri Gorici

Tel.: +386 5 33 93 000

Fax: +386 5 33 93 801

E-mail: info@iskra-ae.com

www.iskra-ae.com

**DISTRIBUTION NETWORK****BELARUS**

IskRa o. o. o.  
Ul. Dombrovskogo 69  
230002 Grodno  
Tel.: +375 152 487 484  
Tel/Fax: +375 152 487 485  
E-mail: iskra@mail.grodno.by

**BOSNIA AND HERZEGOVINA**

Iskra AE Komponente, d. o. o.  
Nemanjina 35  
78250 Laktaši  
Tel.: +387 51 53 07 85  
Fax: +387 51 53 53 15  
E-mail: iskra-ae@inecco.net

**BRAZIL**

Iskra do Brasil Ltda.  
Rua Testa n. 81 -  
Jardim Sao Sebastiao  
Jaguariuna - (SP)  
CEP 13820-000  
Tel.: +55 19 3837 2363  
Fax: +55 19 3837 3185  
E-mail: uros.kravos@iskra-ae.com  
www.iskra-ae.com.br

**CHINA**

Iskra Suzhou Autoelectric Co., Ltd.  
Wenzhou Industrial Zone Shuangfeng  
Taicang, Jiangsu Province  
Tel: +86 512 8160 6888  
Fax: +86 512 8160 7799  
E-mail: iskrasuzhou@iskra-ae.com  
www.iskra-ae.com.cn

Changchun Fawer  
Iskra Automotive Electrical Co., Ltd.  
No. 2258 Pudong Road  
Changchun Economic  
Technology Development Zone  
Changchun, Jilin Province  
Tel.: +86 431 461 5016  
Fax: +86 431 461 5017  
E-mail: zhj\_fa@faw.com.cn

**FRANCE**

Iskra Autoelectrique S.A.S.  
ZA du Chapeau Rouge  
56000 Vannes  
Tel.: +33 2 97 45 59 90  
Fax: +33 2 97 45 59 99  
E-mail: iskra@iskra-sa.fr  
www.iskra-ae.fr

**GERMANY**

Iskra Deutschland GmbH  
Danziger Strasse 1  
71691 Freiberg am Neckar  
Tel.: +49 7141 702 69 0  
Fax: +49 7141 702 69 33  
E-mail: info@iskra-ae.de  
www.iskra-ae.de

**GREAT BRITAIN**

Iskra UK Ltd.  
Redlands  
Ullswater Crescent, Coulsdon  
Surrey CR5 2HT  
Tel.: +44 208 668 7141  
Fax: +44 208 668 3108  
E-mail: sales@iskra-agency.co.uk  
www.iskra-ae.co.uk

**IRAN**

Iskra Autoelectric Iran JVC  
No.28, East Mirdamad Avenue  
Tehran 15469-34311  
Tel.: +98 21 2 226 237 1 - 4  
Fax: +98 21 2 226 237 6  
E-mail: info@iskra-iran.com

**ITALY**

Iskra Autel S. r. l.  
Via G. Cantore, 2  
34170 Gorizia  
Tel.: +39 0481 536 800  
Fax: +39 0481 536 810  
E-mail: info@iskra-autel.it  
www.iskra-autel.it

**RUSSIA**

Iskra Avtoelektrika  
Representative Office  
Storozhevaya str., 4,  
building 1 office 123  
111020 Moscow  
Tel.: +7 095 726 93 94  
Fax: +7 095 225 84 06  
E-mail: info@iskra-ae.ru  
www.iskra-ae.ru

**SPAIN**

Iskra Autoelectrique Spain S.A.  
Calle Llobatona No. 6-D  
08840 Viladecans  
Tel.: +34 93 647 40 83  
Fax: +34 93 647 40 84  
E-mail: iskra@iskra-ae.es

**USA**

Iskra AE Inc.  
10 Corbin Drive, Suite 4  
Darien, CT-06820  
Tel.: +1 800 474 1996  
Tel.: +1 203 655 2884  
Fax: +1 203 655 1965  
E-mail: iskra@iskraae.com  
www.iskraae.com

Iskra AE, Inc. (OEM Sales Office)  
4814 American Road  
Rockford, IL 61109  
Tel.: +1 815 874 4022  
Fax: +1 815 874 4024