

S T A R T E R M O T O R S

T Y P E	AZD	AZE	AZF	AZG	AZJ
----------------	-----	-----	-----	-----	-----



Iskra

Iskra Avtoelektrika d.d.



MAIN TECHNICAL DATA

Type	AZE65...- nose / AZE66...- noseless	
Nominal voltage (V)	12	24
Rated power (kW)	2.6	3.0
Length-nose	< 205	< 205
Length-noseless (mm)	< 243	< 243
Weight-nose	5.2	5.2
Weight-noseless (kg)	5.5	5.5
Yoke diameter (mm)	90	
Stator	4-pole windings	
Drive assembly	6 rollers	
Solenoid 12 V	pull-in current < 55 A hold-in current < 15 A	
24 V	pull-in current < 30 A hold-in current < 7,5 A	
Terminals	30 - M8, M10 31 - M8 50 - M4, M5, M6, 6.4 x 0.8	
Basic protection	IP56 protection against ingress of dust, solid foreign objects and splashing water	
Ambient temperature	- 40°C to + 110°C	

STARTER MOTORS WITH REDUCTION GEAR AND ELECTRICAL EXCITATION

These are **starter motors** for starting diesel engines in light commercial vehicles, small tractors and agricultural machinery, ships, stationary generator sets, and other applications.

APPLICATIONS

For diesel engines from 2 to 3.5 litre of capacity.

FEATURES

- High specific power output and efficiency.
- Excellent cold crank capability.
- Reduced weight and dimensions in comparison to direct drive starter motors.
- Nose or nose-less versions for specific applications.
- Different pinions, flanges, and electrical connections adjusted to the specific engines.
- Special versions are available on request for harsh ambient condition

DESIGN

Pre-engaged system of starter motor.

Electrical excitation of the motor part.

Epicyclical reduction gear with sintered ring gear and shock absorbers.

Drive assembly with six rollers clutch.

Pinion shift mechanism with solenoid and fork lever.

Solenoid switch with pull-in and hold-in winding.

High quality thermal resistant materials.
Drive end brackets of die cast aluminum.

O-rings for protection against water ingress and special drain holes.

End-of-life Directive 2000/53/EC respected and also free of asbestos, beryllium and ammonia.

OPTIONS

Dust protection with lip seal on the pinion.

Oil-proof in nose-less version for wet clutch applications.

Insulated ground return version.

CROSS SECTION

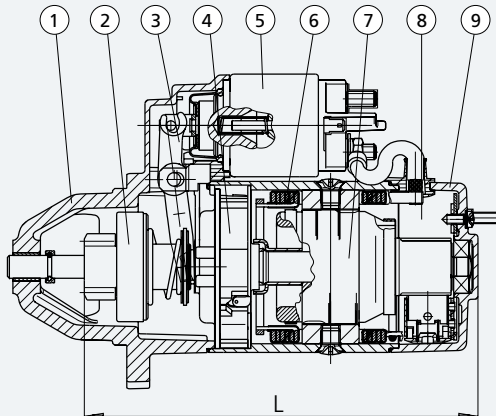

WITH NOSE

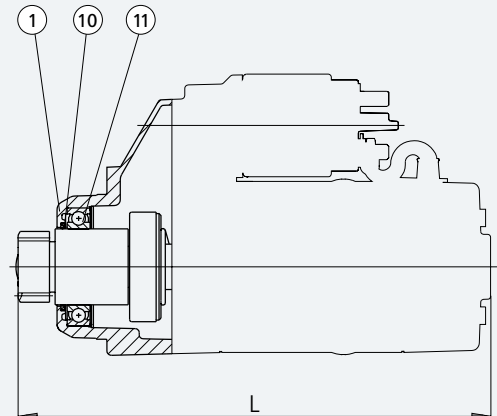

NOSELESS

1. Drive end bracket • 2. Drive assembly • 3. Engaging lever • 4. Reduction gear • 5. Starter switch • 6. Stator
7. Armature • 8. Brush holder • 9. Commutator end bracket • 10. Gasket • 11. Bearing

CONNECTION DIAGRAMS

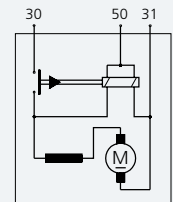
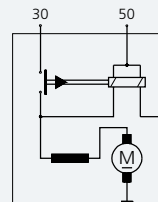

CHARACTERISTICS

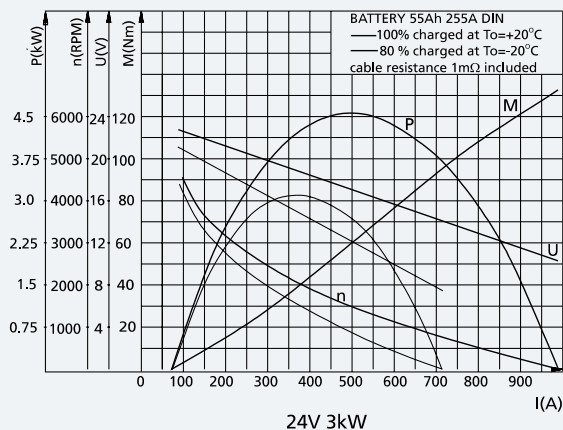
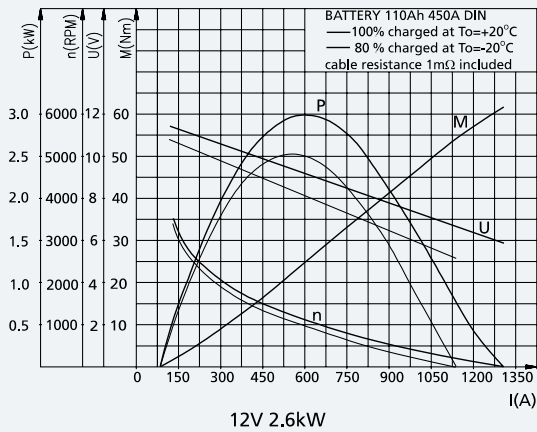

Iskra Avtoelektrika, d. d.

Polje 15, Slovenia,
5290 Šempeter pri Gorici
Tel.: +386 5 33 93 000,
Fax: +386 5 33 93 801
E-mail: info@iskra-ae.com
www.iskra-ae.com

BELARUS

IskRa o. o. o.
Ul. Dombrovskogo 69
230002 Grodno
Tel.: +375 152 487 484
Tel/Fax: +375 152 487 485
E-mail: iskra@mail.grodno.by

BOSNIA AND HERZEGOVINA

Iskra AE Komponente, d. o. o.
Nemanjina 35
78250 Laktaši
Tel.: +387 51 53 07 85
Fax: +387 51 53 53 15
E-mail: iskra-ae@inecco.net

BRAZIL

Iskra do Brasil Ltda.
Rua Testa n. 81 -
Jardim Sao Sebastiao
Jaguariuna - (SP)
CEP 13820-000
Tel.: +55 19 3837 2363
Fax: +55 19 3837 3185
E-mail: uros.kravos@iskra-ae.com
www.iskra-ae.com.br

CHINA

Iskra Suzhou Autoelectric Co., Ltd.
Wenzhou Industrial Zone Shuangfeng
Taicang, Jiangsu Province
Tel: +86 512 8160 6888
Fax: +86 512 8160 7799
E-mail: iskrasuzhou@iskra-ae.com
www.iskra-ae.com.cn

Changchun Fawer
Iskra Automotive Electrical Co., Ltd.
No. 2258 Pudong Road
Changchun Economic
Technology Development Zone
Changchun, Jilin Province
Tel.: +86 431 461 5016
Fax: +86 431 461 5017
E-mail: zhj_fa@faw.com.cn

FRANCE

Iskra Autoelectrique S.A.S.
ZA du Chapeau Rouge
56000 Vannes
Tel.: +33 2 97 45 59 90
Fax: +33 2 97 45 59 99
E-mail: iskra@iskra-sa.fr
www.iskra-ae.fr

GERMANY

Iskra Deutschland GmbH
Danziger Strasse 1
71691 Freiberg am Neckar
Tel.: +49 7141 702 69 0
Fax: +49 7141 702 69 33
E-mail: info@iskra-ae.de
www.iskra-ae.de

GREAT BRITAIN

Iskra UK Ltd.
Redlands
Ullswater Crescent, Coulsdon
Surrey CR5 2HT
Tel.: +44 208 668 7141
Fax: +44 208 668 3108
E-mail: sales@iskra-agency.co.uk
www.iskra-ae.co.uk

IRAN

Iskra Autoelectric Iran JVC
No.28, East Mirdamad Avenue
Tehran 15469-34311
Tel.: +98 21 2 226 237 1 - 4
Fax: +98 21 2 226 237 6
E-mail: info@iskra-iran.com

ITALY

Iskra Autel S. r. l.
Via G. Cantore, 2
34170 Gorizia
Tel.: +39 0481 536 800
Fax: +39 0481 536 810
E-mail: info@iskra-autel.it
www.iskra-autel.it

RUSSIA

Iskra Avtoelektrika
Representative Office
Storozhevaya str., 4,
building 1 office 123
111020 Moscow
Tel.: +7 095 726 93 94
Fax: +7 095 225 84 06
E-mail: info@iskra-ae.ru
www.iskra-ae.ru

Pramo Iskra o.o.o.
Zubcovskoe shosse 21
172387 Rzhev, Tverskaya obl.
Representative office in Moscow
Elektrozavodskaya str. 21
107023 Moscow
Tel. / Fax: +7 495 995 2512
E-mai: iskra@pramo.ru

SPAIN

Iskra Autoelectrique Spain S.A.
Calle Llobatona No. 6-D
08840 Viladecans
Tel.: +34 93 647 40 83
Fax: +34 93 647 40 84
E-mail: iskra@iskra-ae.es
www.iskra-ae.fr/esp/

USA

Iskra AE Inc.
4814 American Road
Rockford, IL 61109
Tel.: +1 800 474 1996
Tel.: +1 815 874 4022
Fax.: +1 815 874 4024
E-mail: iskra@iskraae.com
www.iskraae.com